

## A Novel Energy Efficient Dry Cleaning Method for Solar Cells Dust Removal

Abdul Basit Taj<sup>1\*</sup>, Muhammad Arslan Janjua<sup>1</sup>, Hamza Ahmad Raza<sup>1</sup>, Misbah Sattar<sup>2</sup>

### ABSTRACT

*In this study, we present the development of a novel, automated solar photovoltaic (PV) panel cleaning system designed to address the challenges of dust accumulation and water scarcity, particularly in arid and semi-arid regions. The proposed system integrates a hybrid cleaning mechanism that utilizes a combination of water sprinkles, a wiper, and a brush to effectively remove dust and debris from the surface of solar panels. Unlike conventional cleaning systems that consume large volumes of water, our design employs only three controlled sprinkles, significantly minimizing water usage without compromising cleaning efficiency. A key feature of the system is its autonomous control capability, driven by real-time environmental data including humidity, temperature, light intensity, and dust levels. This data is collected via sensors and transmitted to a cloud-based platform for processing. The system is also interconnected with a user-friendly Android application, allowing remote monitoring and manual override when necessary. Performance evaluation indicates a cleaning efficiency of approximately 70%, with a corresponding 6% increase in output power observed after cleaning operations. Designed to be cost-effective for solar PV systems rated above 5 kilowatts (kW), the prototype demonstrated effective cleaning on both L1 and shed-type solar array configurations. Furthermore, the system's modular design makes it adaptable for extension to L2 and L3-array type installations. This solution offers a sustainable alternative for PV maintenance by reducing operational costs and water dependency, thus enhancing long-term energy yield and system reliability. The system holds significant potential for large-scale solar farms operating in environmentally challenging conditions.*

**Keywords:** Efficient dust remover, Less Water Cleaning System, Solar PV maintenance, Sustainable cleaning system, Water efficient technologies,

---

**Author's Affiliation:**

**Institution(s) Name:**

<sup>1</sup>National University of Technology, Islamabad,

<sup>2</sup>COMSATS Lahore,

**Country:**

<sup>1</sup>Pakistan,

**Corresponding Author's Email:**

<sup>1</sup>Abdulbasittaj@nutech.du.pk

\* The material presented by the author does not necessarily portray the view point of the editors/ editorial board and the management of ORIC, Iqra University, Main Campus, Karachi-Pakistan. Published by ORIC, Iqra University, Main Campus, Karachi-Pakistan. This is an open access article under the license <http://creativecommons.org/licenses/by-sa/4.0/>

3105-4528 (Online), 3105-451X (Print) © 2025



## **1. Introduction**

Energy demand all around the world has been increasing tremendously in the last decade. In developing countries like Pakistan it is increasing annually at a rate of 9%. It is expected that by 2050, energy demand will increase to about 20% annually. The world is continuously looking for new power sources and the solar photovoltaic (PV) is one of the abundant energy source. Solar PV modules produces electricity when they are exposed to sun rays and this continuous exposure produces defects in solar modules [1]. The continuous placement of PV modules outside under the sky deposits dust on the module surface. The accumulation of the dust lowers the output power of the module and sometimes causes severe damage. According to a study, dust accumulation decreases the solar panels efficiency by 15-30% and it depends on the location of the solar panel such as deserts and coastal areas [2]. Residential solar system is also equally vulnerable to the loss due to soiling. It is estimated that a 5 kW PV system with 30% soiling loss will produce 4 units less than expected. Solar PV users especially commercial ones invest on cleaning the modules regularly to get the desired output and the cleaning techniques use water as a fluid [3]. It is a real challenge to bring water in desert and barren areas where commercial PV systems are normally installed. In this work, we proposed a hybrid cleaning approach that uses air to blow off the dust first and then scrubbing through water bubbles to clean the dust and it is achieved with minimum use of water compared to existing techniques [4]. The technique used in this work uses less amount of water to clean the panels hence it can tackle the water scarcity issue in barren deserted areas. The cost of this setup is less than the existing systems and it takes the input energy from solar panel itself hence it is less costly and energy efficient model.

This Project is aimed at developing a self-cleaning solar PV module cleaning solution that requires less amount of water. Manual cleaning of large-scale solar installations can be time-consuming and labor-intensive. Automated cleaning systems, such as robotic or waterless cleaning systems, enable efficient and faster cleaning of multiple panels simultaneously, reducing the maintenance workload and associated costs.

## **2. Related Work**

Large-scale solar farms or projects are deployed in deserts or places where sunlight remains for 8-10 hours during the day. In such environments where issues like soiling, moisture, and dust build-up on solar panel surfaces cause a huge rift in the power generation capacity of solar plants. To avoid such issues,

both traditional and modern cleaning solutions are being used in industry to clean solar panels. Due to the advancement of materials and robotics, traditional methods such as manual cleaning of solar panels are going to be obsolete. Modern solutions such as robotics, cleaning kits, etc. are available to clean a panel effectively. Solar panels are cleaned manually by using different techniques and tools along with the help of an operator. Cleaning kits is the most common type of manual cleaning tools used which include extension poles, carrying bags, brushes, clothes, hose connections, and more [5]. High torque to volume ratio, the flexible structure, and the high positioning precision make Piezoelectric actuators top priority to use in various optical adjustments, biomedical manipulation and space exploration. Such systems are used to clean solar panels by using water as a cleaning agent and spreading it to a depth of 0.1 to 1 mm during the rarefaction cycle of compression waves. A vacuum is created in liquid during rarefaction called ultrasonic cavity and this cavity sucks the dust from the solar panels [6]. A translucent self-cleaning nano-film can be coated onto the surface of solar panels to prevent dust deposition. This nano-film is composed of either super-hydrophilic or super-hydrophobic materials. The super-hydrophilicity method relies on rainwater to disperse across the solar module and cleanse the dust particles. However, this approach is not widely adopted due to the limited availability of rainfall in solar farm locations. Alternatively, super-hydrophobic materials facilitate the rapid removal of water droplets, carrying away dust particles like the lotus leaf effect. However, careful examination is needed to assess the practicality of implementing these materials on solar panels, as solar farms are typically situated in regions with infrequent rainfall [7][8]. There are two hot ways to clean the solar panels: Using water solvent cleaning agent, and with special brushes that do not require water. Nowadays most solar panel practices involve a robotic system that incorporates above mentioned practices. The selection of practices may change depending upon the location, and seasonal variations in the area where solar plants are deployed. These systems use water as a primary component for cleaning solar panels. Water-based systems are suited in urban and tropical climates where is abundantly available. A manufacturer name 'Serbot Swiss innovations' developed a cleaning system for mobile deployment onto photovoltaic panels that cleans through a rotating brush and de-mineralized water. The designed system is controlled via a radio and is easy to transfer place to place [9]. A strong observation led to a conclusion that the waterless cleaning is a more effective cleaning method in dry places where water is scarce such as the desert. A brush

is used as a dust repellent to wipe the dust from the photovoltaic panels in the waterless cleaning technology. The Solar Brush drone that are Aerial Powered targeting desert regions of the world for the cleaning purpose [10].

[11] studied numerous PV cleaning methodologies cleaning with water and dry cleaning with the help of a mechanical brush, a cloth, compressed air, ultrasound, vibration and many more. [12] revealed that cleaning PV panels with water is worthwhile than dry cleaning but is not feasible in areas having water scarcity.

In a recent study by [13] [14] influence of dust deposition is quantified using temperature and insolation for clean and dirty PV panels. The overall performance of the PV system is studied based on a comparison of quantified and recorded data. Lastly, different cleaning methodologies are studied to procure the best ones. Power losses were brought down to 7% when PV panels were cleaned fortnightly, which is the most feasible interval in terms of balance between cleaning cost and energy wasted due to soiling.

### **3. Methodology**

The Figure 1 shows the flow chart and Figure 2 shows the organization of this research work. The Simulation of the proposed system is performed using Proteus software. The hardware part consists of three separate cleaning mechanisms that are deployed after on another in the cleaning process. The first stage includes spraying of the compressed air on the panel with the help of a nozzle to clean dust and remove sand. As the system is intended for deployment in water-scarce regions, the first stage serves as a key dry-cleaning operation. In addition to compressed air, future designs will investigate electrostatic dust removal methods and rotating dry brushes to fully eliminate water dependency. These dry-cleaning techniques are essential for improving energy output in remote desert locations where water logistics pose significant operational challenges. Limit switches are used at both ends of the panel to signal the completion of a specific stage. In the second stage, the machine moves back to its initial starting point. Low-density flexible polyurethane foam roller is used to wipe the surface of the panel. In the third stage, the compressor sprays air to remove any dust that remains after the roller moves over its surface. Figure 2 also shows how the system makes the algorithm work and what functions are performed by the system in a specific order. To calculate the accuracy of the system the output power of the PV panel was monitored before and after the cleaning. Due to accumulation of the duct the power difference was observed

and compared with the clean module output power. The difference in the power determined the accuracy of the system.

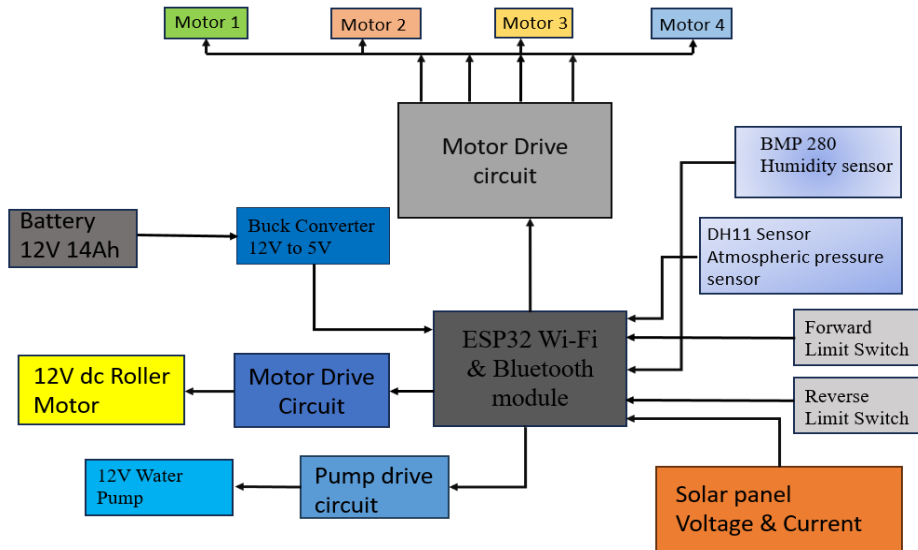

*Figure 1. Flow chart of the proposed system showing the steps and method adopted.*

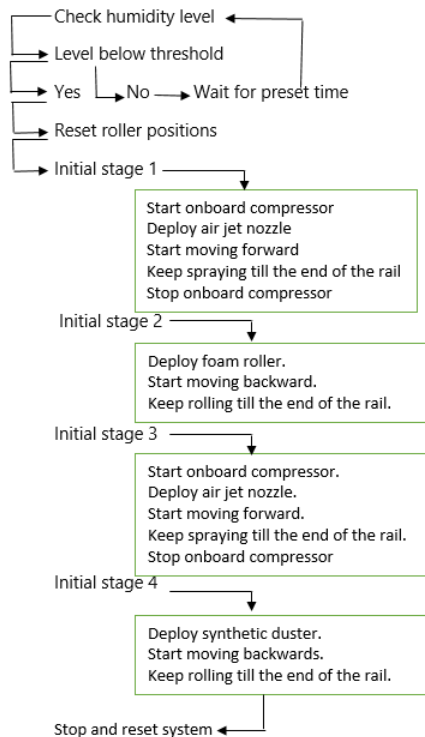
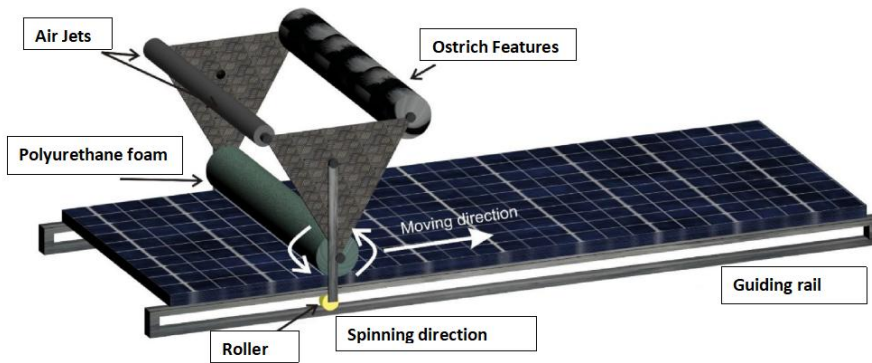

*Figure 2. Methodology of the proposed system*

### **3.1 Hardware Design**

In this work we used two-step cleaning techniques. Firstly, an exhaust fan removed dust from solar panels quickly. Secondly, a wiper with a soft cloth is used to wipe the panel surface with the help of a robotic system. The main components used in the project are Micro-controller Arduino Uno, a DC gear motor, Buck-Boost Converter, and Motor Drive Module. Furthermore, four different types of dust are used to demonstrate the cleaning process. Such a system is a requirement in areas having high environmental dust such as deserts or semi-arid areas. In the robotic part we used 5 dc motors. Two motor acts as horizontal drives along the row level of solar panels, while two motor acts as vertical drives (up and down movement) on the solar panel. The fifth dc motor is used to rotate the microfiber component that cleans and maintains stability in the vertical motion of the robotic system. The ultrasonic sensor is used to measure the distance travelled by the robot across the panel surface. Figure 3 shows the prototype design and view of hardware moving on the solar panel. The proposed model in this paper utilizes two different controlling units: A robotic Unit and Autonomous Unit that communicate through an internet Cloud-based platform known as UBIDOTS. The robotic unit acts as a slave of the autonomous unit and UBIDOTS interface directly under the operator's command. To further strengthen system usability, the Android application is planned to be upgraded with real-time system diagnostics, predictive maintenance notifications, and automated software updates for the robotic unit. Future versions will also enable voice-based controls and weather-responsive scheduling using forecast data integration. These features will significantly improve operational efficiency, user interaction, and system autonomy. The robotic unit moves the frame across the solar panel. Solar panels start and end is detected by two limit switches. The autonomous unit commands the robotic unit to perform the cleaning on the solar panel. It also contains different sensors to sense humidity, temperature and light intensity, dust density, and output power to automate the cleaning process. Humidity sensor is used to operate the system during the day time when there is less humidity in air. Figure 4 shows the robotic unit for the above-mentioned system in running condition. To address minor dust residues observed when operating without the water pump, we propose integrating a vacuum-based suction mechanism as a fourth stage in the cleaning cycle. This mechanism would help lift residual particles and prevent accumulation near the panel edges. Furthermore, replacing the soft cloth with a spongy rubber brush or microfiber roller is under consideration to enhance dust retention without streaking. Future iterations of the robotic mechanism will include encoder-based motor control for

precise movement, ensuring uniform coverage and minimizing dust displacement.



*Figure 3. Prototype of the proposed system showing the movement of the foam on the solar panel surface*

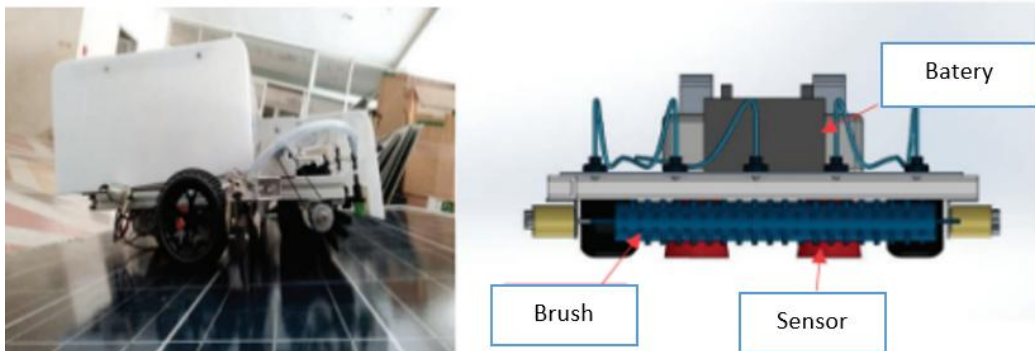

*Figure 4. Side view and electrical parts. Left side image showing the roving roller and right side showing the electrical components installed*

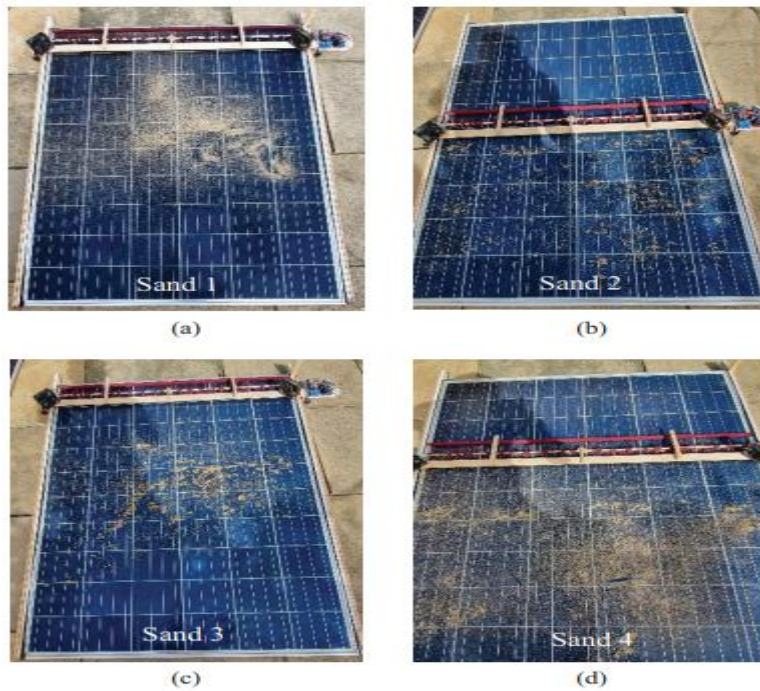

*Figure 5. Top view of the solar panel showing sand deposition on the solar panel. (a) shows dense sand on top side (b) shows equal deposition of sand on all cells (c) shows less dense sand on center (d) shows dense sand on bottom side of the panel*

### **3.2 Model Design**

The simulation model of the system is shown in Figure 6. Hardware designing of this system mechanism involves the calculation of various parameters such as the weight of the frame and speed and torque of the motor that is required to move the system across the panel. To calculate the total weight of the moving mechanism following mechanical parts are considered.

- Windscreen Wiper weight
- Roller Brush Shaft
- Rectangular frame
- Trolley Tires
- Water pump weight
- Battery weight
- Mechanism Movement Holding Shaft
- Coupling for tightening Purpose
- Miscellaneous weight

Overall cost of the system accumulated to 63k pkr and the breakdown of the cost is mentioned in Table 1. The cost of the solar panel is not mentioned here as it is not included in the cleaning system. It is the testing object. Cost of each component used in making the prototype of the proposed system except the cost of solar panel.

*Table 1. Cost breakdown of the project*

<b>Sr No</b>	<b>Component</b>	<b>Price (pkr)</b>	<b>Sr No</b>	<b>Component</b>	<b>Price (pkr)</b>
1	ESP32 Wi-fi Module	2500	7	12V Relay	350
2	ESP32 Usage		8	12V Water Pump	2000
3	DHT11 Humidity Sensor	400	9	Battery	25000
4	Limit Switch	300	10	Motor Mount	1000
5	BMP 280 Atmospheric Pressure Sensor	800	11	Dc Gear Motor	3000
6	LM2596 Buck Converter	500	12	Rods Shaft With Frame Structure	5000

*Table 2. Model design parameters with maximum and minimum values of the electrical*

<b>Sr No</b>	<b>Parameter</b>	<b>Max Value</b>	<b>Min value</b>	<b>Modality/Platform</b>
1	Operating Voltage	14 V	12 V	Li-Po battery
2	Current	10 A	7 A	-
3	Torque (One Motor)	1.2 N.m	0.8 N.m	Dc gear Motor
4	Mass	12 Kg	9 Kg	-
5	Power	140 W	84 W	Electrical Power
6	Communication	-	-	Wi-fi
7	Processor Speed (Main CPU)	2.4 GHz	-	32-bit Quad Core
8	Clock Speed	8 MHz	-	ESP 32

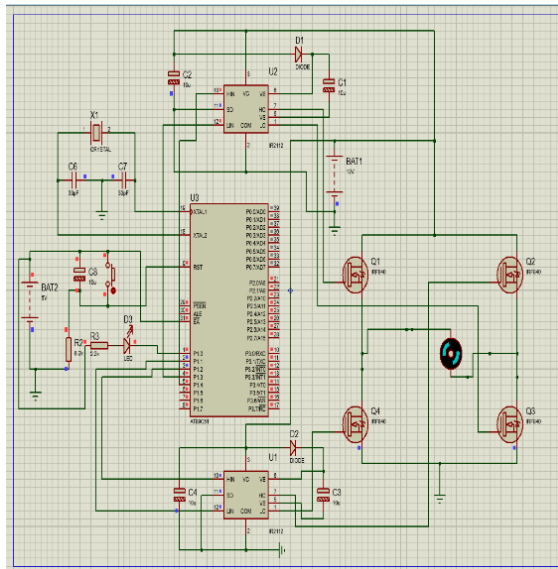

*Figure 6. Simulation of the proposed system on the proteus software.*

#### **4. Results and Analysis**

It is observed a dirty solar panel does not produce the maximum output current due to less absorption of sunlight. Table 3 shows a comparison between the output voltage and current values before and after cleaning the solar panel. It is observed that after cleaning the solar panel, the power generated by the solar panel has seen a significant increase. The increase in power corresponds to an increase in the efficiency of the system. Solar panels are source of green energy. Higher the power they produce more green energy inserted into the system. Usage of less water to clean the solar cells and increase the power indirectly add more green effect towards the solar cell green energy. Since our solar panel is damaged the system may show irregularities in data. These are due to the breakage of solar panels. We are comparing different data from the sensors to decide on the best value for each parameter so the system may know at what instance should cleaning mechanism should be operated. Manual operation is also a viable solution if data is not being monitored or there is a crash in internet service. Increasing the dust density (as shown in Figure 5) decreases the output power. The values of dust densities were not noted down but the effect of the density on the power was clearly observed.

*Table 3. Values of voltage current and power before and after cleaning the solar panel.*

	<b>Voltage (V)</b>	<b>Current (A)</b>	<b>Power (W)</b>	<b>% Increase in Power</b>
<b>Before Cleaning</b>	20	6	120	6.13
<b>After Cleaning</b>	19.9	6.4	127.36	

#### **4.1 Humidity vs Temperature at daytime and Night-time**

The Table 4 shows the comparison between humidity and temperature during the daytime and night time over a period of one month.

#### **4.2 Graph between Humidity Vs temperature at Daytime**

Since it is summer season in June, due to high temperatures, humidity varies from 40 % to 70 % during the daytime

*Table 4 . Humidity Vs Temperature sensor data comparison for one month starting from 1st june and ends on 29th June*

<b>Dated</b>	<b>Temp daytime (°C)</b>	<b>Temp nighttime (°C)</b>	<b>Humidity Daytime</b>	<b>Humidity nighttime</b>
<b>1-Jun-23</b>	26	17	43	50
<b>3-Jun-23</b>	33	19	41	58
<b>5-Jun-23</b>	36	22	44	62
<b>7-Jun-23</b>	34	23	43	51
<b>9-Jun-23</b>	39	25	67	56
<b>11-Jun-23</b>	36	24	49	57
<b>13-Jun-23</b>	39	26	63	58
<b>15-Jun-23</b>	34	23	47	62
<b>17-Jun-23</b>	38	28	59	65
<b>19-Jun-23</b>	39	23	64	65
<b>21-Jun-23</b>	41	31	68	67
<b>23-Jun-23</b>	40	27	64	62
<b>25-Jun-23</b>	42	26	70	65
<b>27-Jun-23</b>	36	25	48	57
<b>29-Jun-23</b>	35	24	46	58

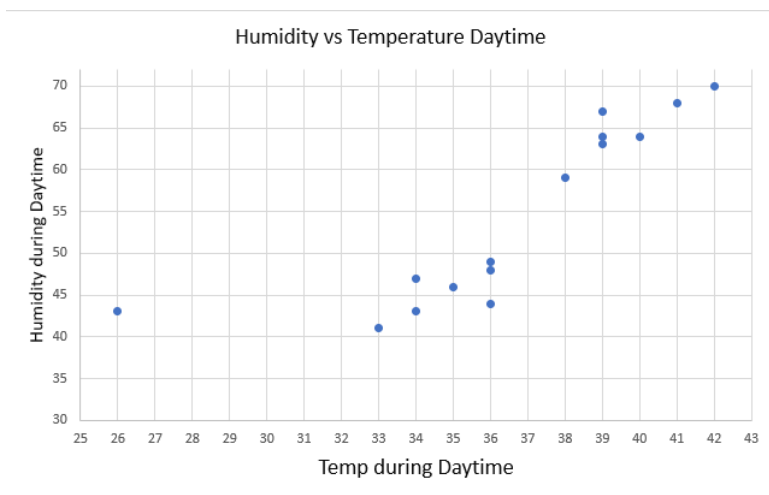

*Figure 7. Humidity Vs Temperature at Daytime*

### 4.3 Graph Between Humidity Vs temperature at Night time

As shown in Figure 8, At nighttime due to temperature drops, the humidity stills vary from 40 to 60 percent so we can say that in normal temperatures day, we can tell our system to decide according to weather forecast data. It is a huge drawback that during the daytime and nighttime, there is no huge change in humidity content in the air. So other parameters can make decisions based on their data.

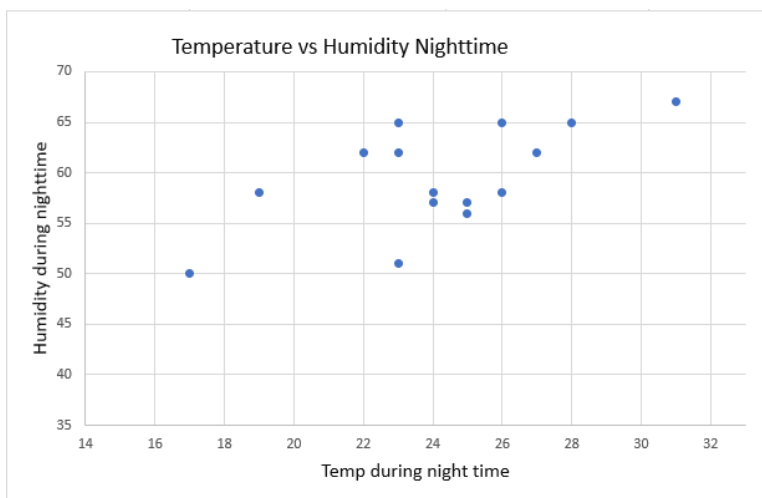

*Figure 8. Temperature Vs Humidity at Night-time*

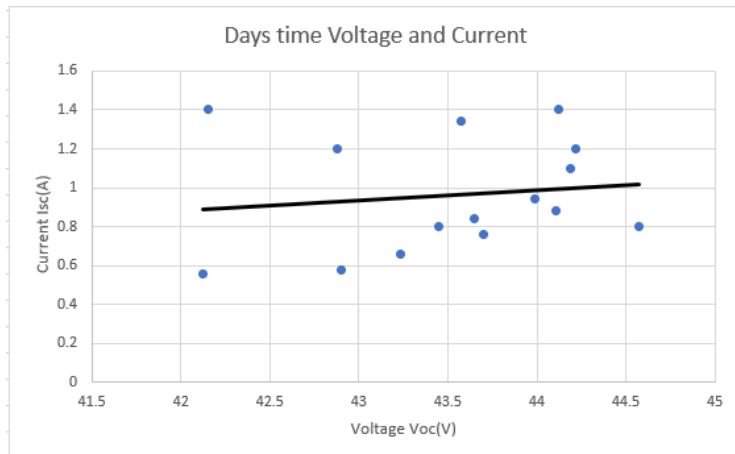

*Figure 9. Comparison between voltage and current data*

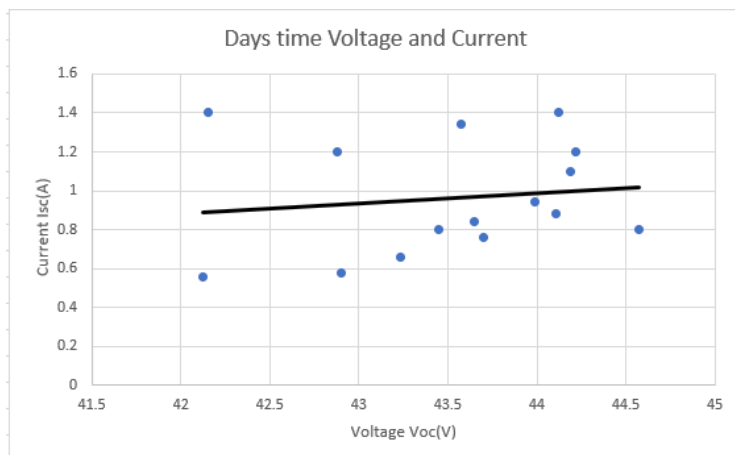

*Figure 10. Voltage Vs Current at night time*

#### **4.4 Voltage and Current Data Comparison**

Figure 10 shows that the solar panel voltage and current directly vary with each other. When the solar panel is not cleaned, the straight line will curve downward showing a decrease in power generation. The solar system will show the maximum power drops when it is in dusty conditions. Since the amount of dust varies from location to location, the voltage during peak sunlight will be high. At nighttime solar system goes on standby producing little to no power so voltage will also drop accordingly.

## **5. Conclusion**

Solar panel cleaning systems play a crucial role in ensuring the optimal performance and efficiency of solar panels. Regular maintenance and cleaning of solar panels can keep them free of dust, debris, dirt, and other atmospheric pollutants present in the air. The cleaner the panel, the more power will be generated by that panel. The designed system provides more accurate cleaning of solar panels when water is used as a solvent but when the water pump is turned off, the cleaning mechanism pushes residual dust towards the panel edges. To resolve this limitation, we plan to incorporate edge-specific cleaning tools such as angled rubber sponges or soft-edge brushes mounted at the sides of the cleaning mechanism. These additions aim to prevent edge accumulation and ensure thorough dust removal even in dry-cleaning mode, thereby improving overall cleaning consistency. To reduce such a drawback, we need a spongy type of rubber that can easily drag excess dust and dirt away from the panel surface when operating in forward model. The system designed will face water availability issues whenever the water tank reaches a dead level. The methodology applied to design the system is feasible if the system is automated and easy to move from panel to panel while cleaning. The decision-making process is dependent upon real-time cloud-based database. The data value if they exceed a certain point then the cleaning mechanism will start its operations. The result achieved during the testing phase of the cleaning mechanism shows that the system is working without interruptions and may need a tweak to the mechanical model to further improve cleaning accuracy and optimal speed. Introducing new sensor such as light intensity, Irradiance meter, and power loss meters etc. to monitor solar system parameters for decision making can enhance efficiency of the proposed system. Future enhancements to the cleaning system include exploring the use of vacuum-based modules to prevent edge accumulation, evaluating alternative brush/wiper materials such as spongy rubber or microfiber for better dry cleaning performance, and refining the motor control algorithm using encoder feedback for more precise and consistent motion. It is strongly recommended to integrate AI algorithms capable of optimizing cleaning schedules, detecting panel degradation patterns, and supporting autonomous decision-making based on real-time environmental and performance data. For enhanced precision, future versions of the system will incorporate advanced environmental sensors, such as irradiance meters, dust concentration sensors, and air quality monitors, alongside temperature and

humidity sensors. These additions will significantly improve the reliability, adaptability, and efficiency of the cleaning system in diverse climates.

## **Declarations**

## **Competing Interests**

The authors declare that they have no competing interests.

## **Authors' Contribution**

All the authors have contributed in the paper.

## **References**

- [1] Nemet, Gregory, and J. Greene, "Innovation in low-energy demand and its implications for policy." *Oxford Open Energy*, vol 1, 2022,
- [2] H. A. Kazem, M. T. Chaichan, A. H. Al-Waeli, K. Sopian, "A review of dust accumulation and cleaning methods for solar photovoltaic systems", *Journal of Cleaner Production*, vol 10, 2020,
- [3] Mejia, Felipe A., and Jan Kleissl. "Soiling losses for solar photovoltaic systems in California." *Solar Energy*, vol. 95, pp. 357-363, 2013,
- [4] G. He, C. Zhou, and Z. Li, 'Review of self-cleaning method for solar cell array,' *Procedia Engineering*, vol. 16, pp. 640-645, 2011,
- [5] X. Lu, Q. Zhang, and J. Hu, 'A linear piezoelectric actuator based solar panel cleaning system,' *Energy*, vol. 60, pp. 401-406, 2013,
- [6] P. Vasiljev, S. Borodinas, R. Bareikis, and A. Struckas, 'Ultrasonic system for solar panel cleaning,' *Sensors and Actuators A: Physical*, vol. 200, pp. 74-78, 2013,
- [7] J. Son et al., 'A practical superhydrophilic self cleaning and antireflective surface for outdoor photovoltaic applications,' *Solar Energy Materials and Solar Cells*, vol. 98, pp. 46-51, 2012,
- [8] G. He, C. Zhou, and Z. Li, 'Review of self-cleaning method for solar cell array,' *Procedia Engineering*, vol. 16, pp. 640-645, 2011,
- [9] S. P. Aly, P. Gandhidasan, N. Barth, and S. Ahzi, "Novel dry cleaning machine for photovoltaic and solar panels," *Proc. 2015 IEEE Int. Renew. Sustain. Energy Conf.*,
- [10] N. Ronnaronglit and N. Maneerat, "A cleaning robot for solar panels," *Proceeding - 5th Int. Conf. Eng. Appl. Sci. Technol. ICEAST 2019*, pp. 1-4, 2019,
- [11] N. Khadka, A. Bista, B. Adhikari, A. Shrestha, and D. Bista, "Smart solar photovoltaic panel cleaning system," *IOP Conf. Ser. Earth Environ. Sci.*, vol. 463, no. 1, pp. 45-57, 2020,

[12] Manju, B., A. Bari, and C. M. Pavan, "Automatic solar panel cleaning system." *International Journal of Advances in Scientific Research and Engineering*, vol. 4, no. 7, 2018, pp. 26–31,

[13] Herraiz, A. H., A. P. Marugán, and F. P. G. Márquez, "A review on condition monitoring system for solar plants based on thermography", *Non-destructive testing and condition monitoring techniques for renewable energy industrial assets*, pp 103-118, 2020,

[14] K. Fatima, A. F. Minai, H. Malik, "Experimental analysis of dust composition impact on Photovoltaic panel Performance: A case study", *Solar Energy*, vol 267, 2024,